

2

1

B

B

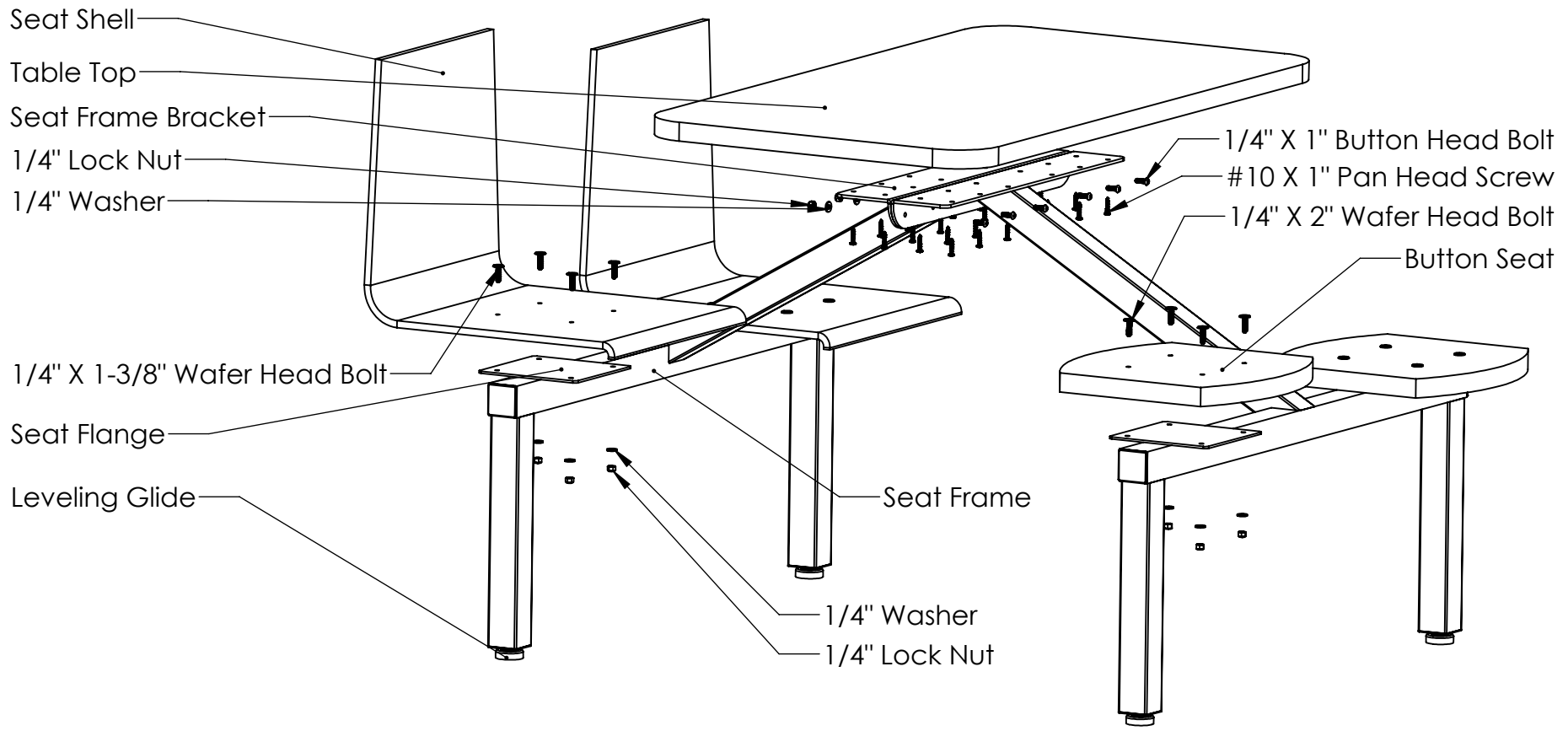

4 Seat Rectangle Cluster Unit Assembly Instructions

Connect the seat frames using the 1/4" Button Head screws, washers and lock nuts. Make sure the Seat Frame Brackets are even along the top. Align the Table Top pilot holes to the Seat Frame Brackets and secure using the #10 X 1" Pan Head screws. Attach the seats to the seat flange using the corresponding Wafer Bolts, washers and lock nuts. Set the unit in place and adjust the Leveling Glides so the unit sits flat on the floor.

A

A

HIGH MARK
 Manufacturing, Inc.
 P.O. Box 212 Johnstown, Co. 80534
 970.587.9044 highmarkmanufacturing.com

2

1