

4 Seat Cluster Unit Assembly

Using the 1/4" X 1" Button Head bolts and 1/4" washers, attach the (X4) seat frames to the spacer adaptor. Make sure the spacer adaptor and the seat frame bracket is flush on the top. Align the pilot holes with the seat frame brackets and secure the top using the #10 Pan Head screws. The seats are attached using the 1/4" Wafer head bolts and washers.



HIGH MARK
 Manufacturing, Inc.
 P.O. Box 212 Johnstown, Co. 80534
 970.587.9044 highmarkmanufacturing.com

2

1

B

B

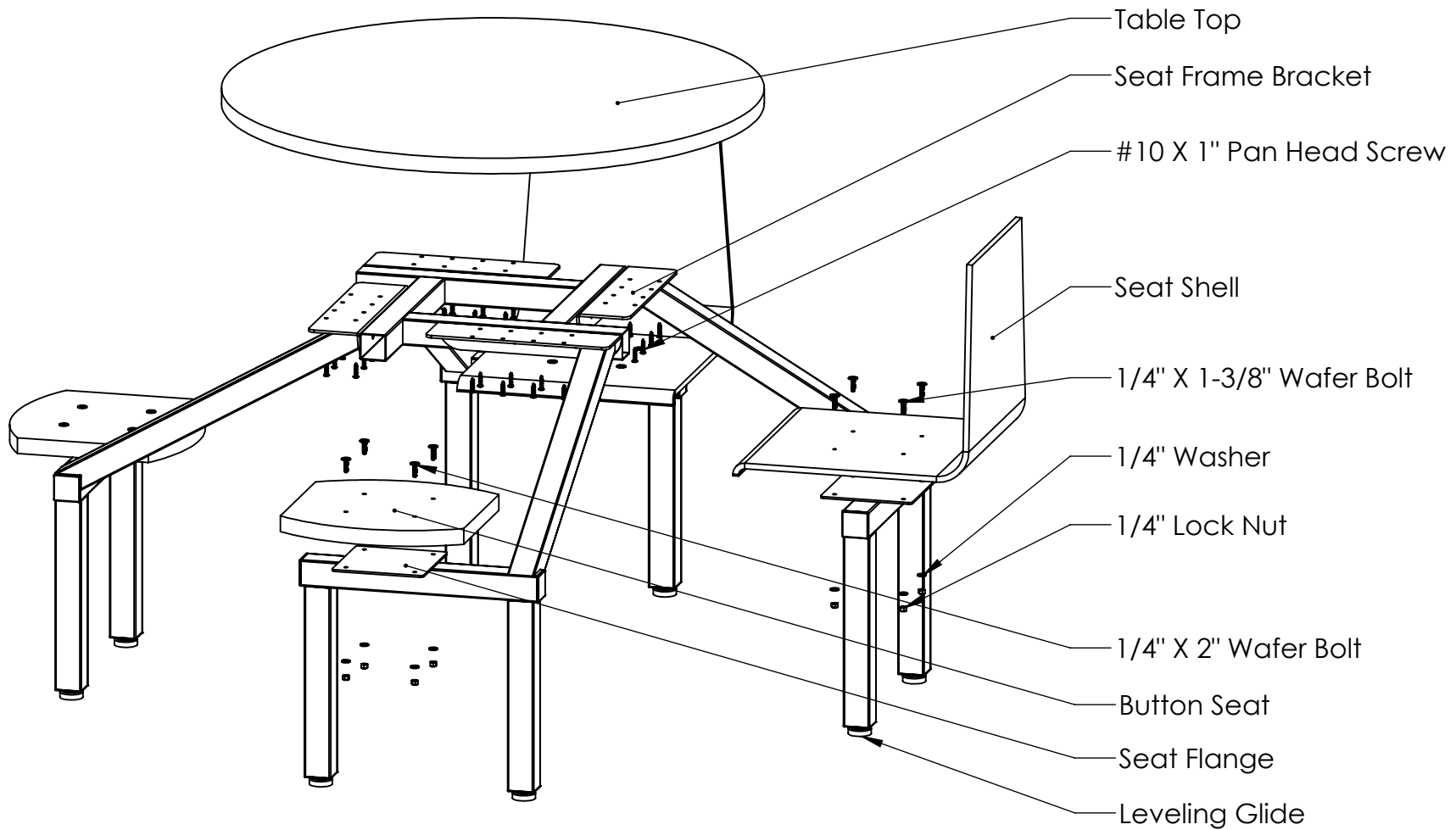

A

A

4 Seat Cluster Unit Assembly

Place the table top onto the frame and align the holes to the seat frame brackets. Using the #10 X 1" Pan Head screws, attach the top to the frame. Place the seats onto the seat flange. Attach the seats using the corresponding wafer bolt, washer and lock nut. Set unit in place and adjust the leveling glides so the Cluster Unit sits flat on the floor.



2

1