

2

1

B

B

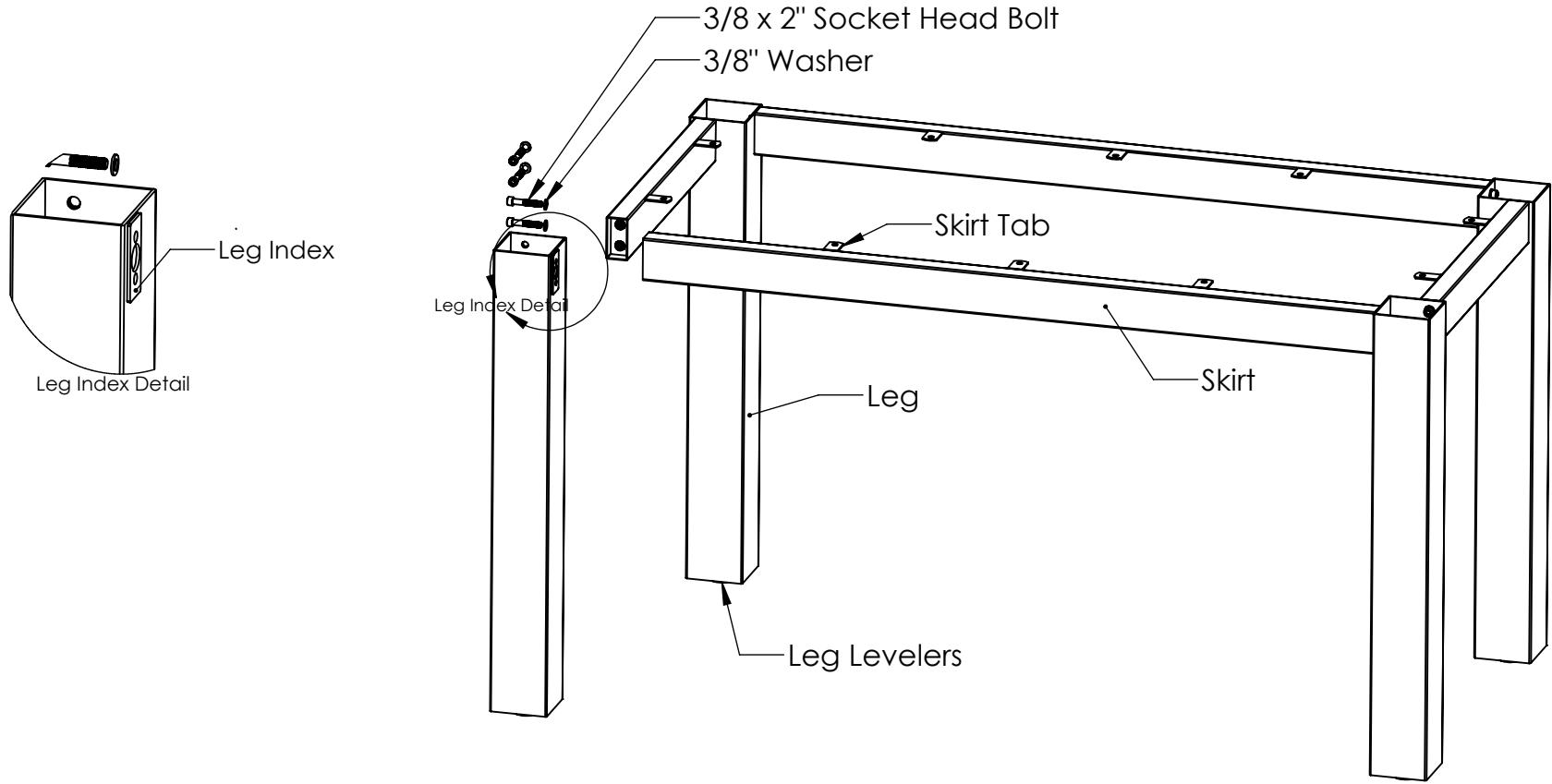

A

A

4 Post Table Base Assembly Instructions

The skirts and legs are assembled by sliding the end of the skirt onto the leg index. They are fastened from the inside of the leg with 3/8" x 2" Socket head bolts and washers. A 5/16" hex socket or allen wrench will be needed. Adjust the leg levelers so the table sits flat on the floor.



HIGH MARK
 Manufacturing, Inc.
 P.O. Box 212 Johnstown, Co. 80534
 970.587.9044 highmarkmanufacturing.com

2

1

2

1

B

B

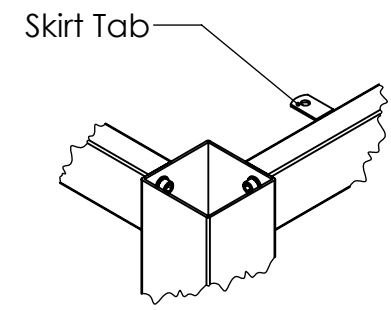
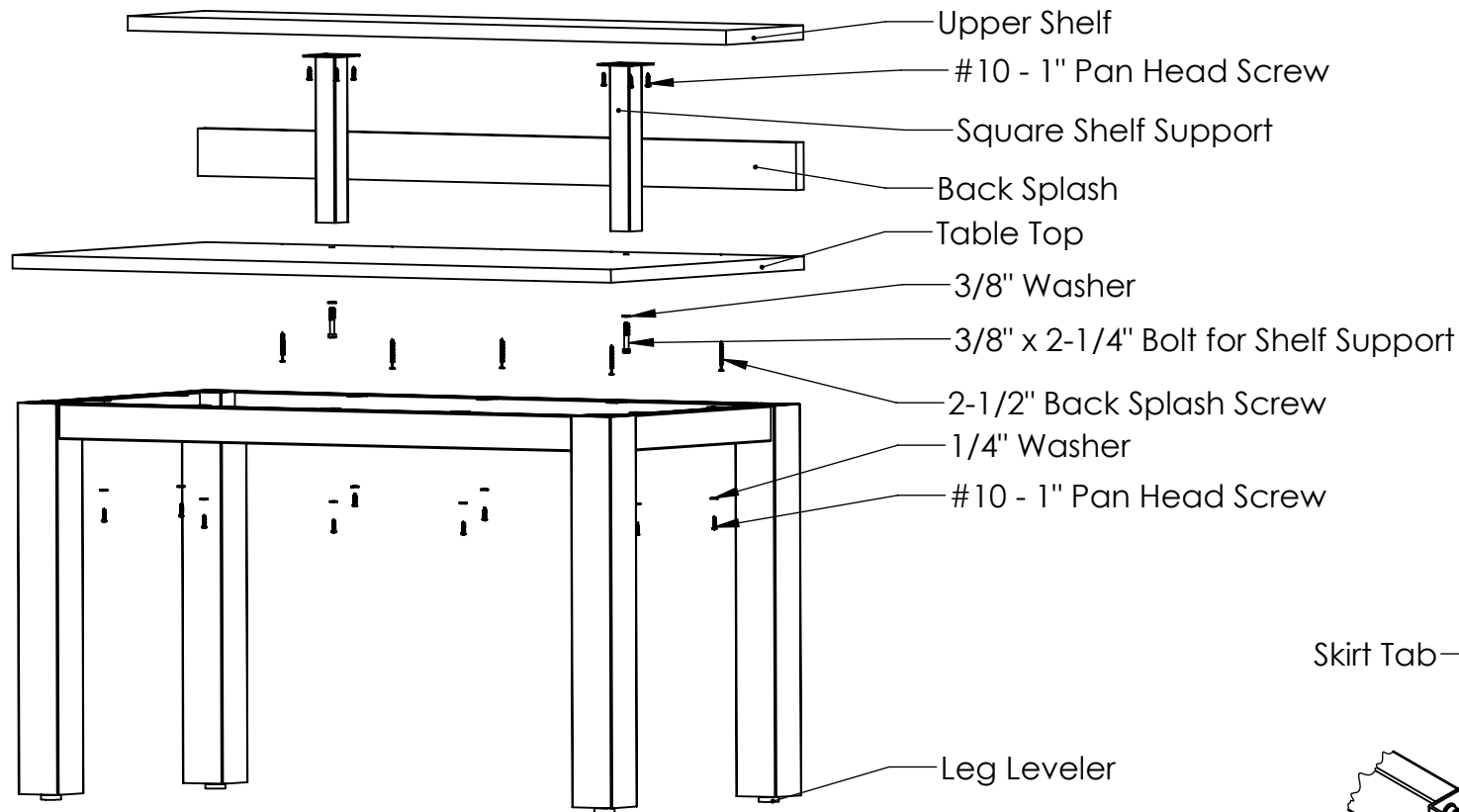

Skirt Tab Detail

4 Post Table Top Assembly Instructions

Place the Table top face up on the base.
 If you have a back splash, now is the best time to attach it.
 Install the back splash using the 2-1/2" back splash screws.
 Make sure the screws are flush with the underside of the table.
 Adjust the table top on the base so that the pilot holes in the table line up with the skirt tab holes.
 Attach the table top using the #10 screws and washers.
 If you have an upper shelf, install the shelf supports using the 3/8" X 2-1/4" Bolts and washers.
 Make sure the supports are square to the edges of the table.
 The shelf is attached using the #10 pan head screws.

A

A

HIGH MARK
 Manufacturing, Inc.
 P.O. Box 212 Johnstown, Co. 80534
 970.587.9044 highmarkmanufacturing.com

2

1