

DRAIN TROUGHS



- All troughs are made of sturdy 3/8" ABS plastic, no corrosion
- Troughs are strong enough to support light foot traffic
- Washers can drain in the side or the top
- Drains can be located on either end or on the bottom
- A single lint screen is included, additional screens are optional
- Lint screens are made from 3/16" PVC with 3/8" holes on 3/4" spacing
- Lint screens have built-in safety overflow cutouts
- A lint screen can be installed anywhere, depending on the drain location
- All troughs have a hinged lid over the lint screen area to keep debris out
- Troughs to be installed in ground will have additional support to accommodate the pressure of a concrete pour
- Quicker, easier and less expensive to install than PVC direct-drain systems
- If the trough is ordered with the bulkhead, the trough will come pre-sloped
- Standard size is 12" H x 18" W; custom sizes are available upon request
- Troughs over 12' in length will be built in sections and connected together with flexible fittings
- Troughs are sized to accommodate a complete dump of all machines at once
- Trough drains are approved as a lint filtration system in most cities nationwide
- Trough drains are an excellent choice for either coin laundries or OPL



HIGH MARK
Manufacturing, Inc.

HighMarkManufacturing.com

DRAIN TRENCHES

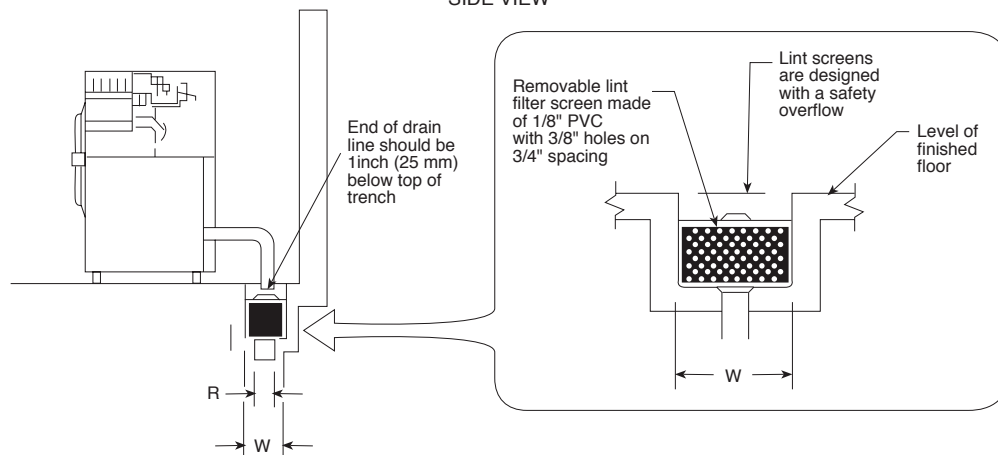
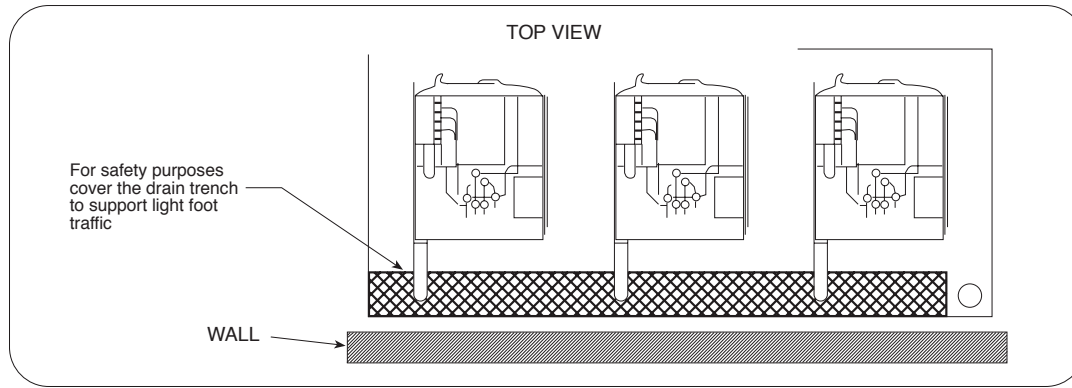
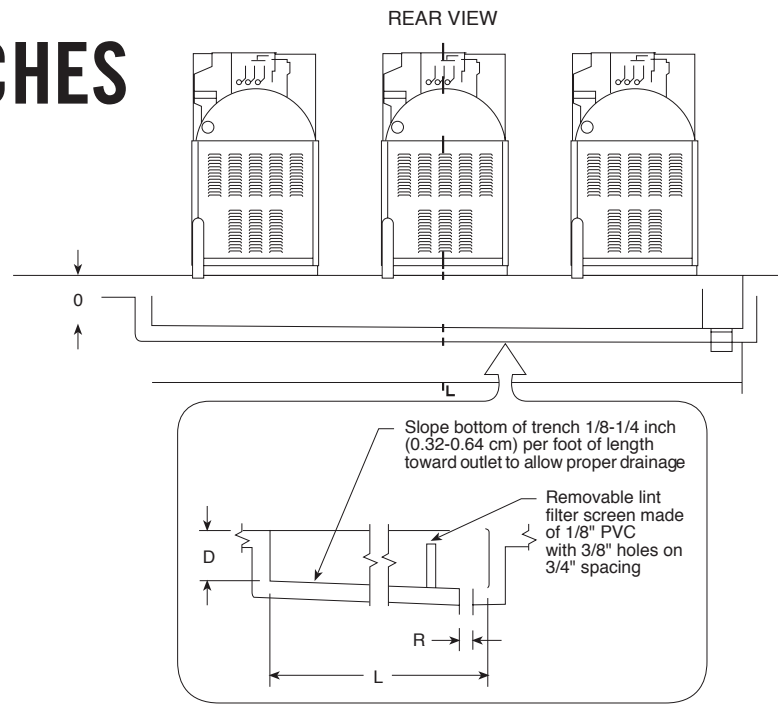

Recommendations for sizing drain lines and drain trenches

A. Determine the total number of gallons that will be dumped at one time by all present and future washers. Use fill volumes at high level to get this total (if only one washer will use the trench, use level at overflow).

NOTE: Always assume worst case, i.e. all washers will drain at the same time from the highest level.

B. Divide the total gallons to drain by 7.48 gallons per cubic foot. The result is the minimum volume of the drain trench in cubic feet.

C. Size the length, width and depth of the trench to meet the above minimum volume and any other parameters, such as washer foundation width, available floor space, etc.

Example: Size a trench for two (2) UW60 and one (1) UW100

Fill levels: UW60 = 24 gallons

UW100 = 50 gallons at high level

Total to drain, gallons = 98 gallons = 2 x 24 gallons + 50 gallons

Drain trench volume in cubic feet =

14.0 cu. ft. (98 gallons ÷ 7.18 gallons/cu. ft.)

Foundation width will be 13 feet 6 inches

(12 inches + 36-5/8 inches + 12 inches + 36-5/8 inches + 12 inches + 41-1/2 inches + 12 inches = 13 feet 6-3/4 inches = 13 feet 6 inches)

Required trench cross section,

square feet = 1.04 sq. ft. = $\frac{(14.0 \text{ cu. feet})}{(14 \text{ feet } 6 \text{ inches})}$

A drain trench with a width of 12 inches and a depth of 13 inches will provide 1.08 sq. ft. cross section.

The drain trench should be 12 inches wide, 13 inches deep and 13 feet 6 inches long. The bottom of the trench should be sloped 1/8 to 1/4 inch per foot of length toward the outlet. For safety purposes the trench should be covered to support light foot traffic.

High Mark Manufacturing, Inc.

P.O. Box 212 • Johnstown, CO 80534

(970) 587-9044; fax: (970) 587-9045

info@highmarkmanufacturing.com