

Assembly Instructions for Benches

STEP 1.

Assemble the base by bolting the spreader bar between the legs as show with 3/16" carriage bolts and flat washers.

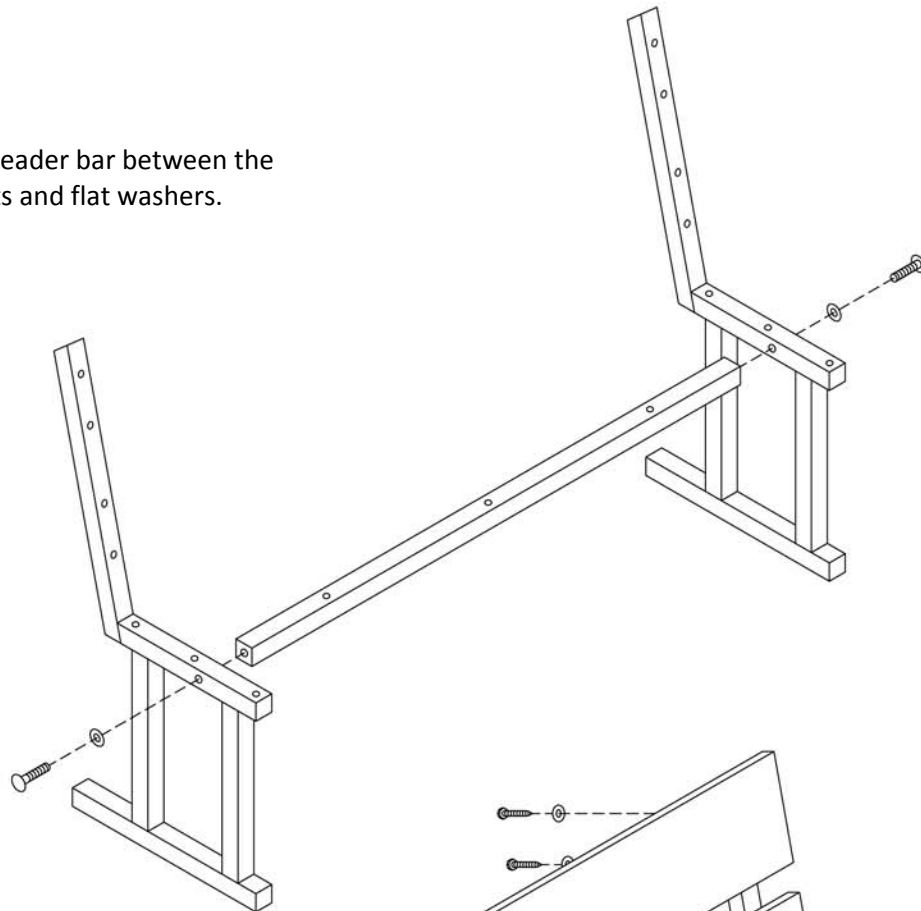

STEP 2.

Mount the seat base and the 2 back slats to the assembled frame by installing 2 1/2" hex-head wood screws and washers through the predrilled holes.

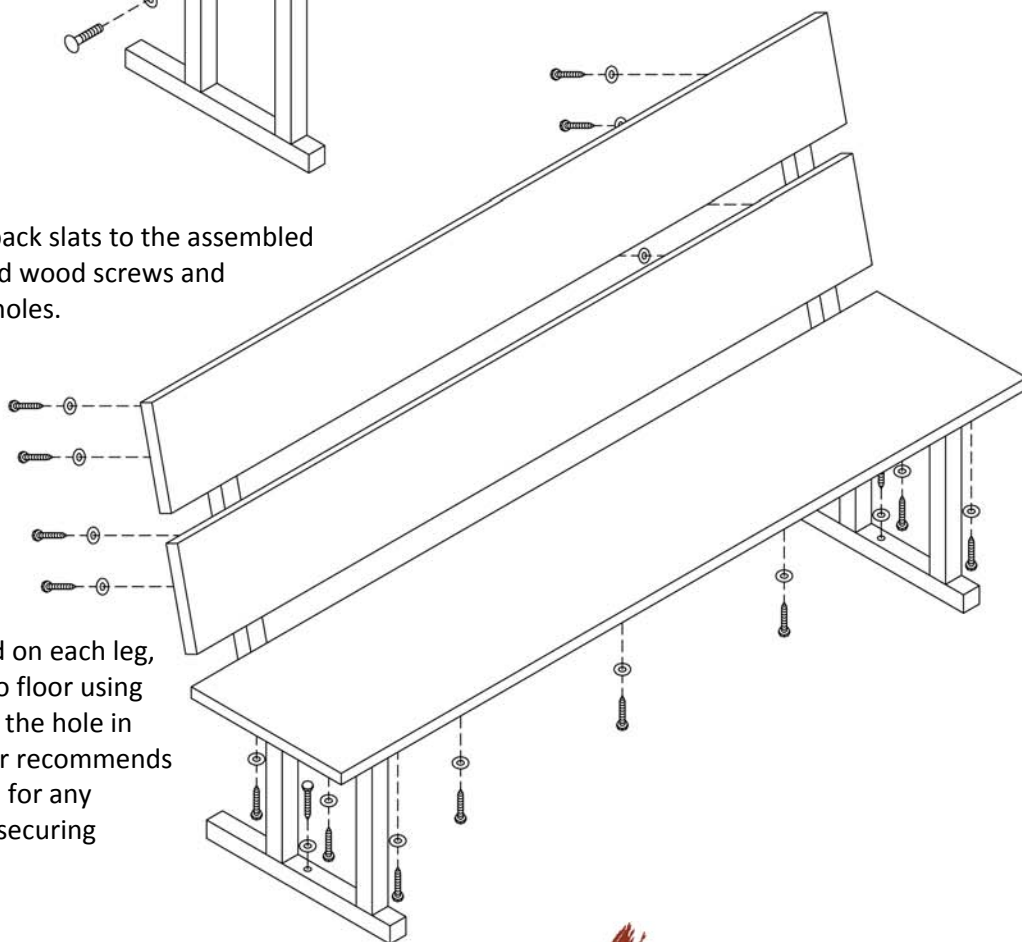

STEP 3.

Using the threaded feet installed on each leg, level the bench. Secure bench to floor using anchor bolt and washer through the hole in each leg assembly. Manufacturer recommends anchoring and is not responsible for any damage or injury caused by not securing bench to floor.